

E1852A Bluetooth™ Test Set



Installation Guide



Agilent Technologies

General

Information contained in this document is subject to change without notice. Agilent Technologies makes no warranty of any kind with regard to this material, including, but not limited to, the implied warranties of merchantability and fitness for a particular purpose. Agilent Technologies shall not be liable for errors contained herein or for incidental or consequential damages in connection with the furnishings, performance, or use of this material. No part of this document may be photocopied, reproduced, or translated to another language without the prior written consent of Agilent Technologies.

The E1852A is listed as a Development Tool for Bluetooth SIG purposes.

Copyright 2001 Agilent Technologies
Station Road, South Queensferry, Scotland,
EH30 9TG, UK.

Bluetooth is a trademark owned by the Bluetooth SIG, Inc.

Microsoft Windows, 95, 98, NT are U.S. registered trademarks of Microsoft Corporation

Pentium is a U.S. registered trademark of Intel Corporation.

Agilent Part No. E1852-90001

Printed in UK

May 2001

Legal Information

Certification

Agilent Technologies certifies that this product met its published specifications at the time of shipment from the factory. Agilent Technologies further certifies that its calibration measurements are traceable to the United States National Institute of Standards and Technology, to the extent allowed by the Institute's calibration facility, and to the calibration facilities of other International Standards Organization members.

Warranty

This Agilent Technologies instrument product is warranted against defects in material and workmanship for a period of three years from date of shipment. During the warranty period, Agilent Technologies will at its option, either repair or replace products which prove to be defective. For warranty service or repair, this product must be returned to a service facility designated by Agilent Technologies. Buyer shall prepay shipping charges to Agilent Technologies and Agilent Technologies shall pay shipping charges, duties, and taxes for products returned to Agilent Technologies from another country. Agilent Technologies warrants that its software and firmware designated by Agilent Technologies for use with an instrument will execute its programming instructions when properly installed on that instrument. Agilent Technologies does not warrant that the operation of the instrument, or firmware will be uninterrupted or error free.

Limitation of Warranty





The foregoing warranty shall not apply to defects resulting from improper or inadequate maintenance by Buyer, Buyer-supplied software or interfacing, unauthorized modification or misuse, operation outside of the environmental specifications for the product, or improper site preparation or maintenance. NO OTHER WARRANTY IS EXPRESSED OR IMPLIED. AGILENT TECHNOLOGIES SPECIFICALLY DISCLAIMS THE IMPLIED WARRANTIES OF MERCHANTABILITY AND FITNESS FOR A PARTICULAR PURPOSE.

Exclusive Remedies

THE REMEDIES PROVIDED HEREIN ARE BUYER'S SOLE AND EXCLUSIVE REMEDIES. AGILENT TECHNOLOGIES SHALL NOT BE LIABLE FOR ANY DIRECT, INDIRECT, SPECIAL, INCIDENTAL, OR CONSEQUENTIAL DAMAGES, WHETHER BASED ON CONTRACT, TORT, OR ANY OTHER LEGAL THEORY.

Safety Symbols

The following symbols on the instrument and in the documentation indicate precautions which must be taken to maintain safe operation of the instrument.

	The Instruction Documentation Symbol. The product is marked with this symbol when it is necessary for the user to refer to the instructions in the supplied documentation.
	Alternating current (AC)
	This symbol indicates the operating switch for 'On' mode.
	This symbol indicates the position of the operating switch for 'Off' mode.
	This symbol indicates that a device, or part of a device, may be susceptible to electrostatic discharges (ESD) which can result in damage to the product. Observe ESD precautions given on the product, or its user documentation, when handling equipment bearing this mark

Safety Notices

This guide uses warnings and cautions to denote hazards

WARNING

A warning calls attention to a procedure, practice or the like, which, if not correctly performed or adhered to, could result in injury or loss of life. Do not proceed beyond a warning until the indicated conditions are fully understood and met.

CAUTION

A caution calls attention to a procedure, practice or the like which, if not correctly performed or adhered to, could result in damage to or the destruction of part or all of the equipment. Do not proceed beyond a caution until the indicated conditions are fully understood and met.

General Safety Information

The following general safety precautions must be observed during all phases of operation, service, and repair of this instrument. Failure to comply with these precautions or with specific warnings elsewhere in this manual violates safety standards of design, manufacture, and intended use of the instrument. Agilent Technologies assumes no liability for the customer's failure to comply with these requirements.

WARNING

This is a Safety Class I instrument (provided with a protective earthing ground, incorporated in the power cord). The mains plug shall only be inserted in a socket outlet provided with a protective earth contact. Any interruption of the protective conductor inside or outside of the instrument is likely to make the instrument dangerous. Intentional interruption is prohibited.

DO NOT defeat the earth-grounding protection by using an extension cable, power cable, or auto transformer without a protective ground connector. If you are using an auto transformer, make sure its common terminal is connected to the protective earth contact of the power source outlet socket.

DO NOT operate the product in an explosive atmosphere or in the presence of flammable gasses or fumes.

DO NOT use repaired fuses or short-circuited fuseholders: For continued protection against fire, replace the line fuse(s) only with fuse(s) of the same voltage and current rating and type.

DO NOT perform procedures involving cover or shield removal unless you are qualified to do so. Operating personnel must not remove equipment covers or shields. Procedures involving the removal of covers and shields are for use by service-trained personnel only.

DO NOT service or adjust alone: Under certain conditions, dangerous voltages may exist even with the equipment switched off. To avoid dangerous electrical shock, service personnel must not attempt internal service or adjustment unless another person, capable of rendering first aid and resuscitation, is present.

DO NOT operate damaged equipment: Whenever it is possible that the safety protection features built into this product have been impaired, either through physical damage, excessive moisture, or any other reason, **REMOVE POWER** and do not use the product until safe operation can be verified by service-trained personnel. If necessary, return the product to a Agilent Sales and Service Office for service and repair to ensure the safety features are maintained.

DO NOT substitute parts or modify equipment: Because of the danger of introducing additional hazards, do not install substitute parts or perform any unauthorized modification to the product. Return the product to an Agilent Sales and Service Office for service and repair to ensure the safety features are maintained.

Safety Symbols	3
----------------------	---

Getting Started

Welcome	10
Unpacking the E1852A Bluetooth Test Set	11
Initial Inspection	11
Documentation Information	12
Conventions Used in this Guide	12
Abbreviations Used in this Guide	12
Specifications	12
E1852A Bluetooth Test Set Installation	13
Powering On	14
Rack Mounting	17
Rear Panel Connections	18
Front Panel Connections	25
Installing the PC Software	26
Minimum System Requirements	26
Install the User Interface	27
Confidence Test	31

Regulatory Information

General Specifications	36
Compliance and Markings	38
Electromagnetic Compatibility (EMC)	38
Safety	38
Markings	39
Regulatory Information	40
Sound Emission	40
Responsibilities of the Customer	42
Agilent Sales and Service Offices	43





Getting Started



Welcome

Welcome to the Agilent Technologies E1852A Bluetooth Test Set *Installation Guide*.

The E1852A Bluetooth Test Set only has status indicators on its front panel. You cannot control it from the front panel. Instead, the test set is controlled entirely by the remote commands applied to the parallel interface port. You can use the Windows based User Interface supplied on the CD-ROM for stand alone applications. Or, you can create your own software to control the test set if you want to include it as part of a more complex test system. The Windows based User Interface and remote commands are fully described in the E1852A Bluetooth Test Set *Operating Guide*.

The *Installation Guide* is divided into the following sections:

- Unpacking the E1852A Bluetooth Test Set
- Documentation Information
- E1852A Bluetooth Test Set Installation
- Installing the PC Software
- General Specifications
- Compliance and Markings
- Regulatory Information
- Responsibilities of the Customer
- Agilent Sales and Service Offices

Unpacking the E1852A Bluetooth Test Set

Initial Inspection

Please inspect the shipping container for damage. If the shipping container or packaging material is damaged, it should be kept until the contents have been checked mechanically and electrically. If there is mechanical damage, notify the nearest Agilent Technologies office (page 43). Keep the damaged shipping materials (if any) for inspection by the carrier and an Agilent representative.

Documentation Information

This guide is only part of the information supplied. The documentation consists of:

- The *Installation Guide* (this book) - Shows you how to check your bluetooth test set, switch it on and connect it to the Device Under Test.
- The *Operating Guide* - Shows you how to operate your bluetooth test set from the supplied User Interface for a PC or using the remote command set. You can find the *Operating Guide* as an Adobe Acrobat PDF (Portable Document Format) file on the supplied CD-ROM.

Conventions Used in this Guide

The following text conventions are used in this guide.

Run	used to represent the text in the Windows® based user interface
Parameter	used to represent a parameter, value or data in an entry field

Abbreviations Used in this Guide

The following abbreviations are used in this guide.

BD	Bluetooth enabled Device
DUT	Device Under Test

Specifications

General specifications are shown on page 36. Full specifications are listed in the *Operating Guide*.

E1852A Bluetooth Test Set Installation

The E1852A Bluetooth Test Set can be used on the bench top or installed in a 19 inch rack cabinet. This section shows you how to:

- check the operating voltage and fuse rating
- switch on for the first time
- confirm successful power on
- install your bluetooth test set in a 19 inch rack (if required)
- make connections to the rear panel interfaces
- make connections to the front panel interfaces
- install the user interfaces and DLL files on your PC
- perform a confidence check

Powering On

WARNING

Appliance coupler (mains input power cord) is the power disconnect device. Do not position the instrument such that access to the coupler is impaired.

1. Check the Operating Voltage Setting and Fuse Rating.

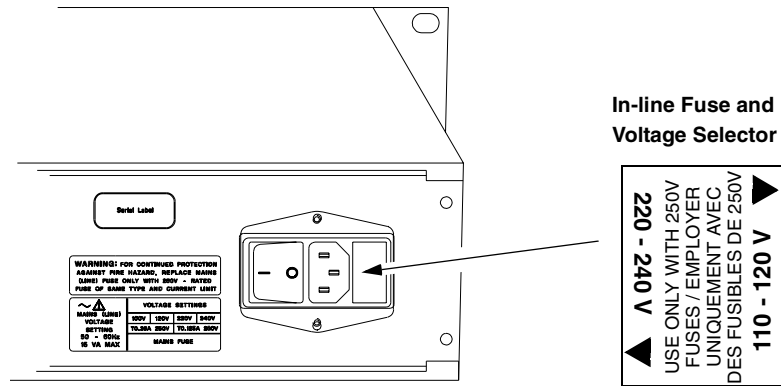

2. Select the required operating voltage by removing and replacing the fuse holder as shown below. Ensure the correct fuse is fitted.

110-120V operation selected
(250mA T fuse)

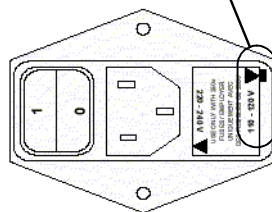

220-240V operation selected
(125mA T fuse)

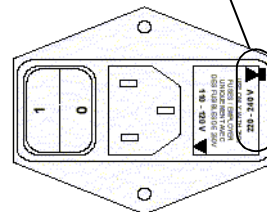

CAUTION

Please ensure you have read and understood the safety information at the front of this guide before proceeding.

CAUTION

Before switching on this instrument, make sure that the line voltage selector is set to the voltage of the power supply and the correct fuse is installed. Ensure the power supply voltage is in the specified range.

3. Connect the Power Cord.

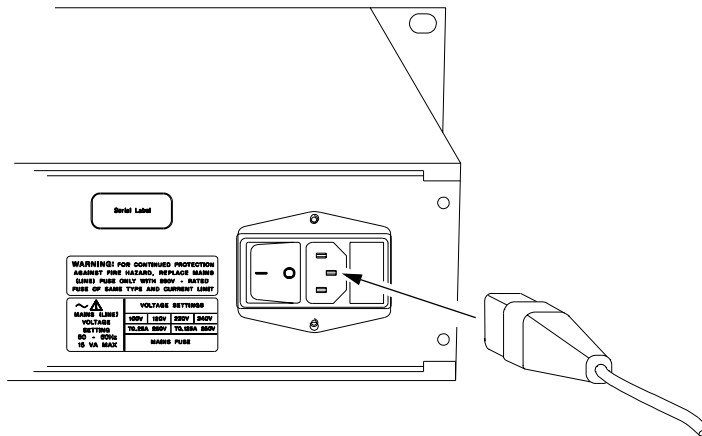

4. Switch the bluetooth test set on by pressing the On (I) switch.

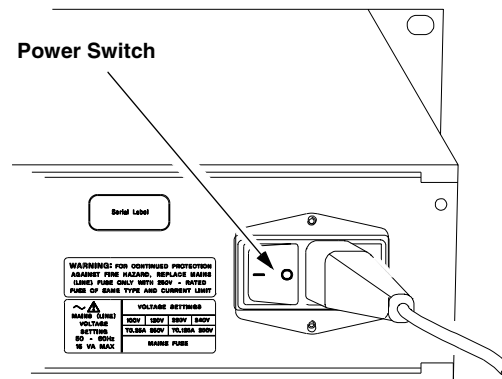

5. During power on, observe that all the front panel LEDs light up for a short time.

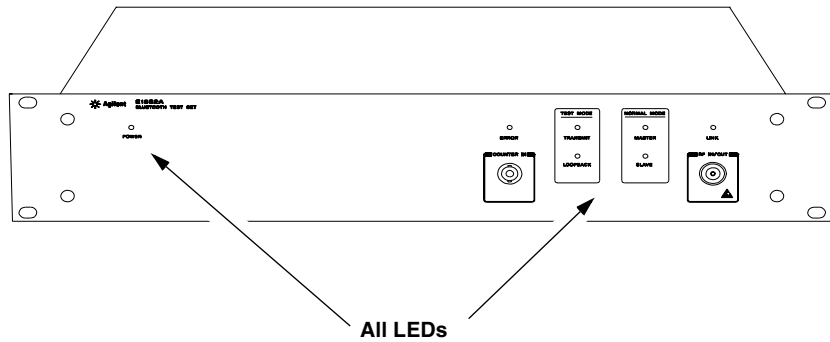

6. After a few seconds, only the Power LED remains lit.

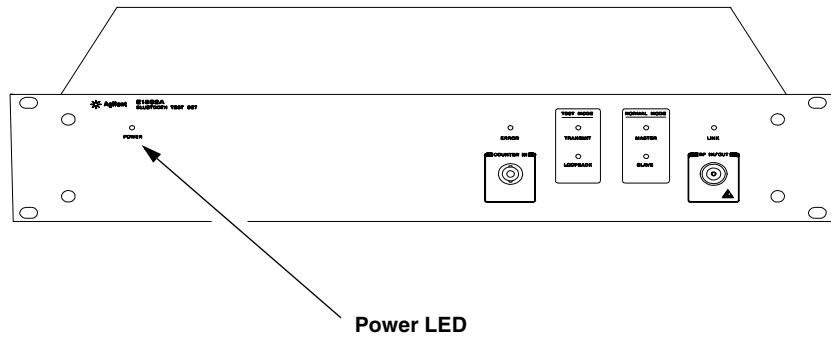

NOTE To ensure your bluetooth test set meets its specifications, ensure the environmental conditions are met and allow a 60 minute warm-up period before making measurements.

Rack Mounting

WARNING

The E1852A is not fitted with a power switch on the front panel. To allow rapid disconnection from mains power when rack mounted, the E1852A shall only be fitted to a rack cabinet with an easily accessible power isolation switch.

1. Dimensions of the test set are shown below. Ensure the space and airflow requirements within the rack cabinet are met.

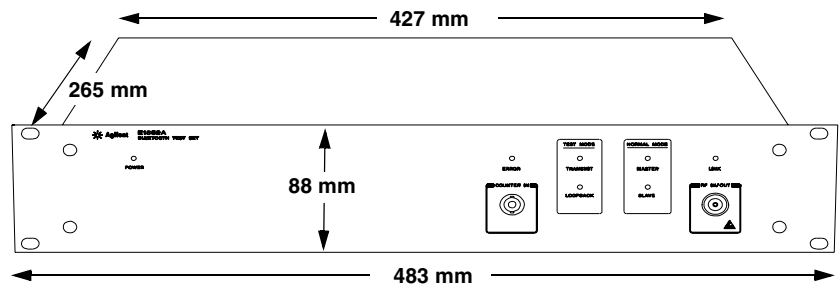

2. Place the bluetooth test set on a system rack shelf and secure it to the frame using 4 screws as shown.

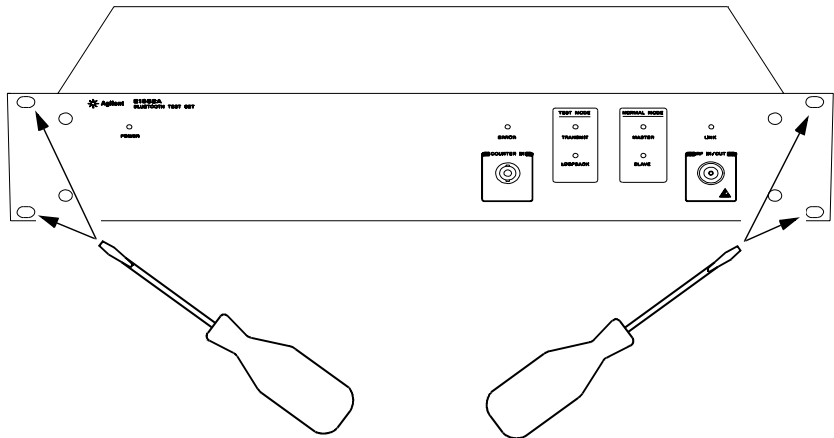

Rear Panel Connections

The E1852A Bluetooth Test Set provides rear panel input/outputs for the following functions:

External Reference	10 MHz timebase signal input
Slot Clock	A 1 μ s wide TTL trigger output at 2.0 times (625 μ s) Bluetooth frame rate
Receive Data	Inverted analogue output of the demodulated signal
Receive Slot Sync	A 1 μ s wide TTL trigger output synchronized with the start of a received burst
Power Envelope	Analog output of the RF power
Parallel Interface	25 pin male D-type connection for communication with a PC
Serial	9 pin female D-type for downloading firmware.
RS-232	RS-232 operation is not supported in this release.

Available connections.

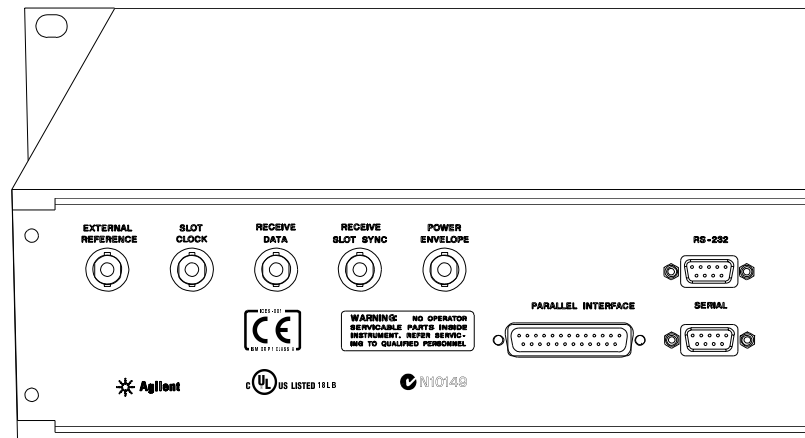

1. To operate the bluetooth test set, you must make a connection from a PC or system controller to the parallel port.

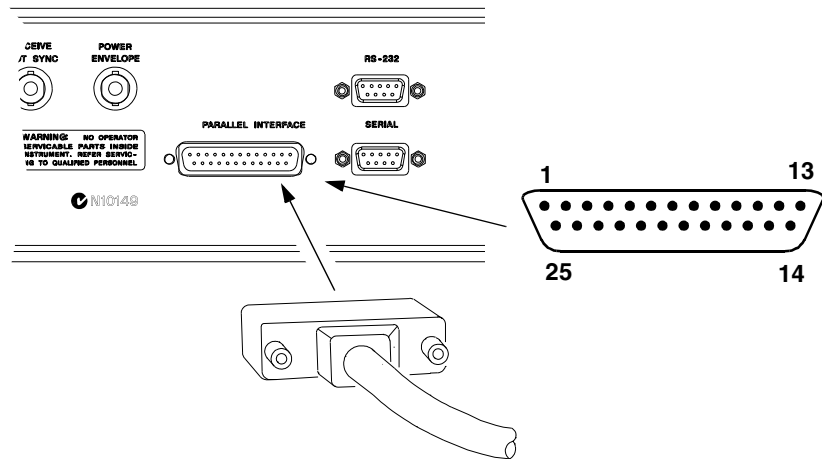

Parallel Interface - male connector configuration.

Pin	Name	Direction	Description
1	PC control Strobe	PC to E1852A	Register strobe/nibble
2	PC_BUS 0	PC to E1852A	Data bit 0
3	PC_BUS 1	PC to E1852A	Data bit 0
4	PC_BUS 2	PC to E1852A	Data bit 0
5	PC_BUS 3	PC to E1852A	Data bit 0
6	PC_BUS 4	PC to E1852A	Data bit 0
7	PC_BUS 5	PC to E1852A	Data bit 0
8	PC_BUS 6	PC to E1852A	Data bit 0
9	PC_BUS 7	PC to E1852A	Data bit 0
10	PC_DOUT 1	E1852A to PC	Data bit 0
11	PC_DOUT 0	E1852A to PC	Data bit 0
12	PC_DOUT 2	E1852A to PC	Data bit 0
13	PC_DOUT 3	E1852A to PC	Data bit 0
14	PC_CTRL 1	PC to E1852A	Register address
15	PC_READY	E1852A to PC	Ready / acknowledge
16	PC_CTRL 2	PC to E1852A	Register address
17	PC_CTRL 0	PC to E1852A	Register address
18-25	GND		Signal Ground

2. Make a BNC connection to the External Reference if you need to synchronize the bluetooth test set to a 10 MHz time base signal. (Sensitivity 150 mV into 50Ω.)

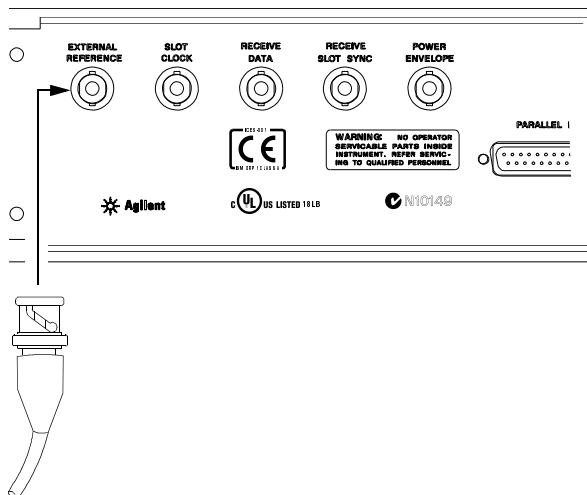

3. Make a BNC connection to the Bluetooth Slot Clock if required (625 μ s interval - TTL level output).

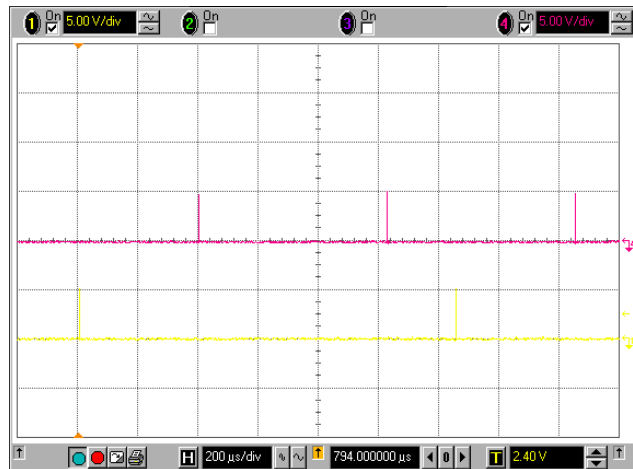
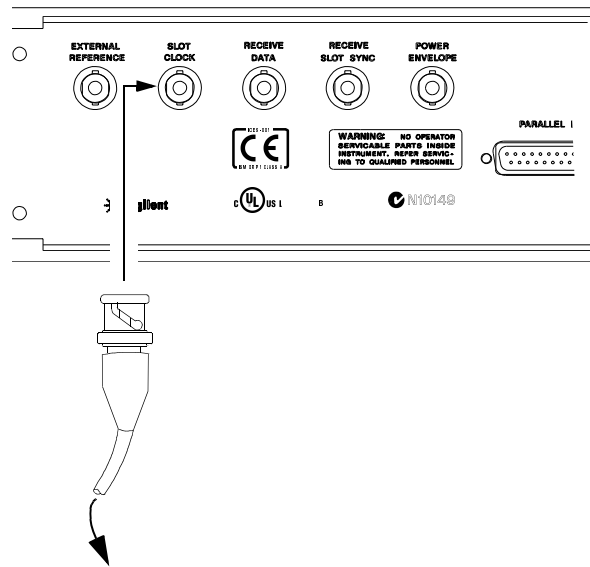

4. Make a BNC connection to the Receive Data if required. (The output is inverted, i.e., zero value data is results in a high output - levels are around 1.5 volts)

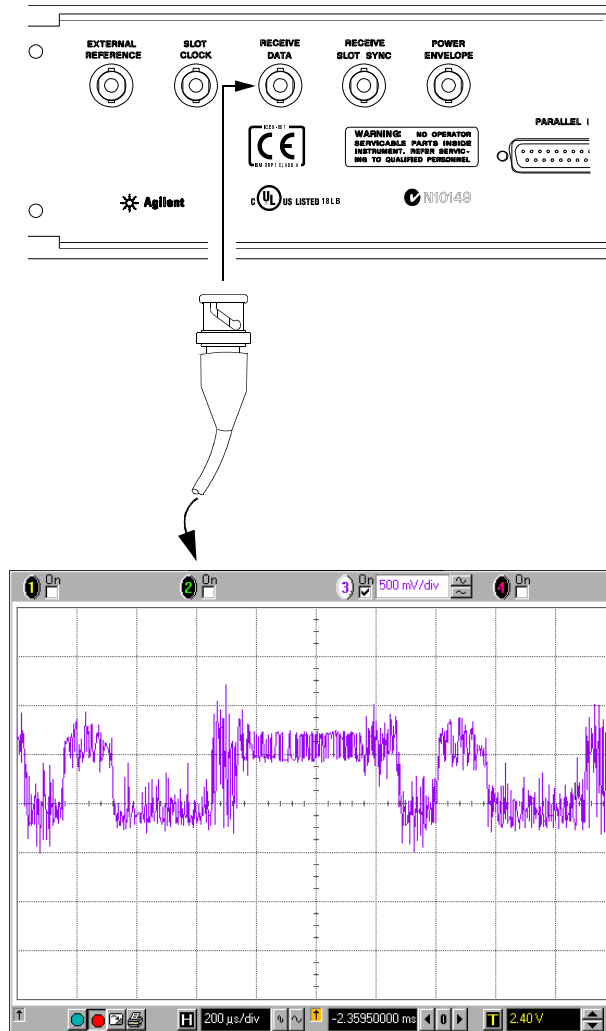

5. Make a BNC connection to the Receive Slot Sync if required. The output is synchronized to the start of the burst. (TTL level output.)

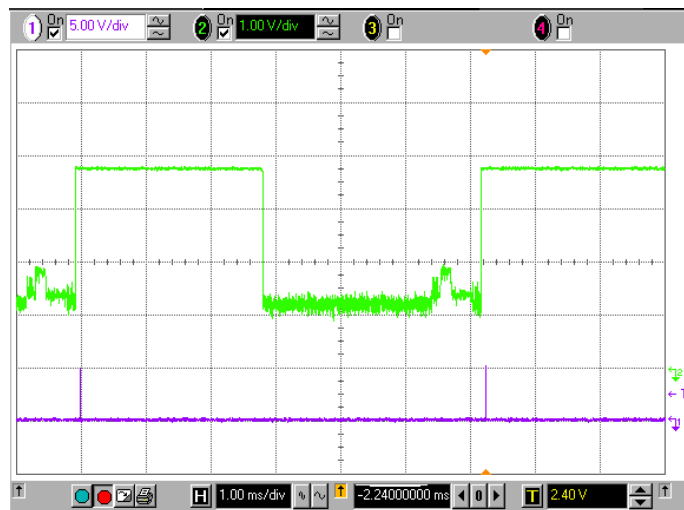
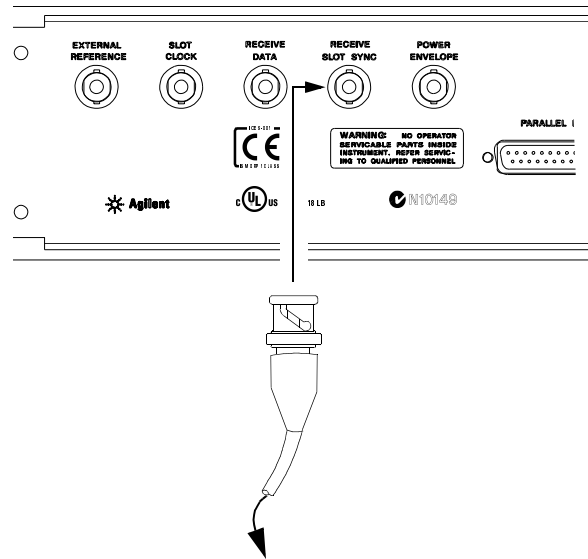

Receive
Slot Sync
Output

6. Make a BNC connection to the Power Envelope if required.

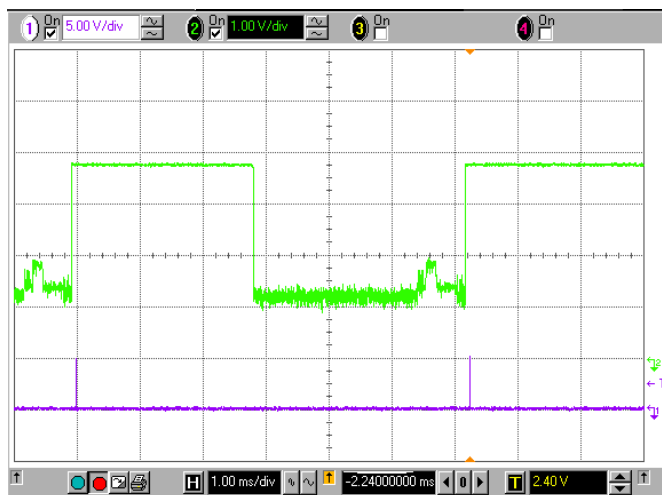
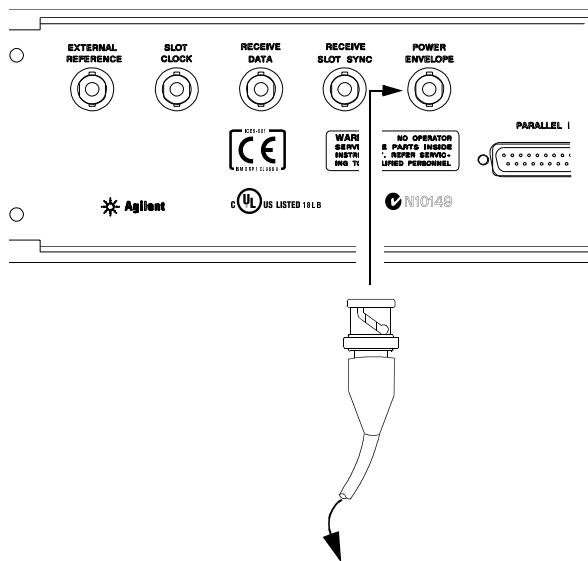

Power
Envelope
Output

Front Panel Connections

The E1852A Bluetooth Test Set provides front panel input/outputs for the following functions:

RF IN/OUT N-type 50 Ω

COUNTER IN Use the counter to measure the frequency of signals up to 15 MHz.

1. Make an RF cable connection between DUT and the RF IN/OUT connector. (To maintain regulatory compliance, antenna coupling with the DUT must be carried out in a screened environment. Antenna coupled measurement results are uncalibrated.)

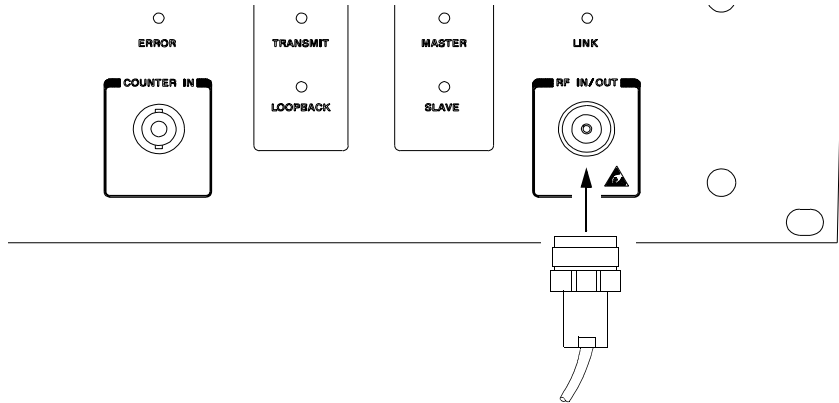

2. A 15 MHz counter is available on the front panel. (High impedance, 500mv rms sensitivity.)

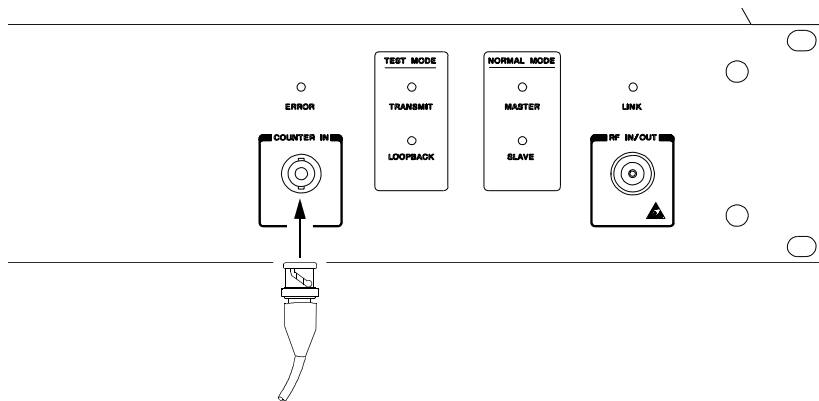

Installing the PC Software

The E1852A Bluetooth Test Set is equipped with a parallel remote programming interface. This section shows you how to:

- install the Windows based User Interface on your PC
- install the Dynamic Link Library (DLL) for remote control purposes
- connect your PC or system controller to the test set

Minimum System Requirements

For successful operation of the User Interface your PC must meet or better the following requirements:

CPU	Pentium 300 MHz
RAM	96 Mbytes
Disc Space	50 Mbytes
Monitor	
Resolution	1024 x 768 pixels (recommended) or higher
CD-ROM drive	yes
Ports	One parallel, one serial
Operating System	Windows 95/98/NT/2000

Install the User Interface

1. Turn on your computer. Insert the E1852A Bluetooth Test Set CD-ROM into your CD-ROM drive.
2. Select **Settings** from **Start** button. Select **Control Panel**.

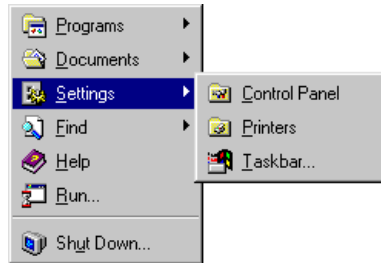

3. Double-click **Add/Remove Programs**.

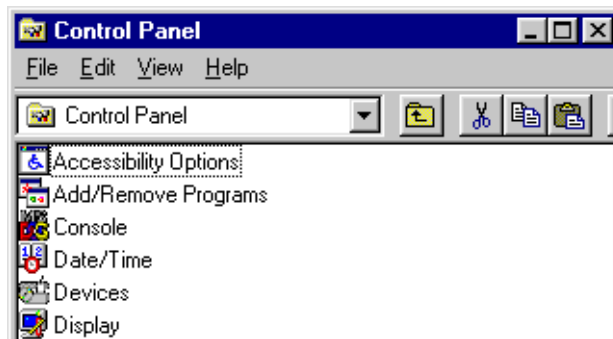

4. Click **Install**.

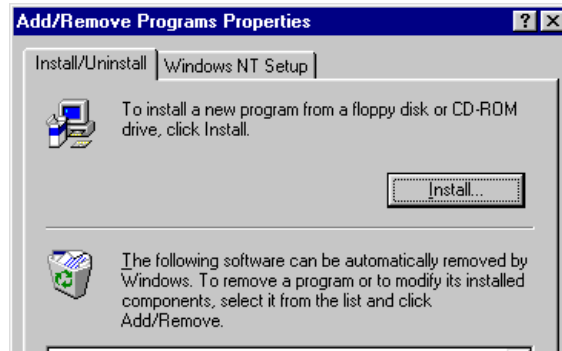

5. Click **Next**. Click browse to find the setup.exe file for the User Interface or enter the path name as shown.

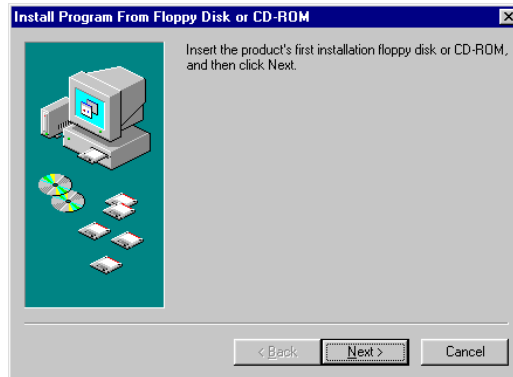

6. Click **Finish**. Use the on screen instructions to guide you through the rest of the installation process. The bluetooth test set User Interface is installed into the directory path: **C:\Program Files\Agilent Technologies\E1852a**.

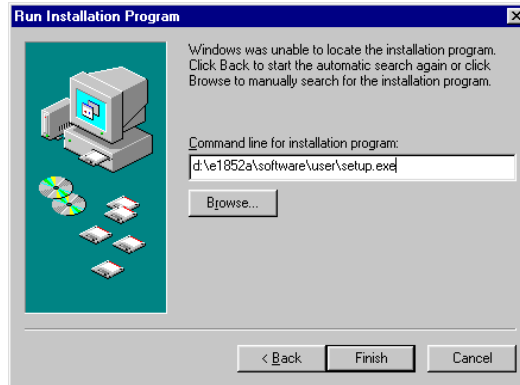

7. When complete, restart your PC. The E1852A Bluetooth Test Set User Interface icon is placed on your PC desktop.



NOTE An additional 'Debug' mode of operation of the Windows interface is available. This can be useful when developing your own test programs. Chapter 4, "Programming Reference" in the E1852A Bluetooth Test Set *Operating Guide* shows you how to access the debug mode.

8. Connect the test set and your PC using the parallel interface connections.

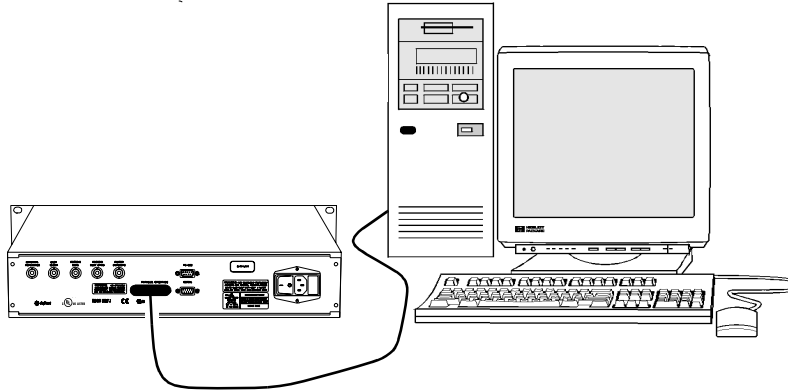

Confidence Test

You can quickly check the operation of your E1852A Bluetooth Test Set.

Ensure that:

- the Windows based user interface is installed on your PC
- the test set is switched on
- your PC and test set are connected using the parallel cable
- no connection to the RF Input/Output connector

-
1. Double click the E1852A Bluetooth Test Set icon (or from the **Start** menu select **Programs, Agilent Technologies, E1852A Bluetooth Tester**).



-
2. During connection, the following message is displayed.

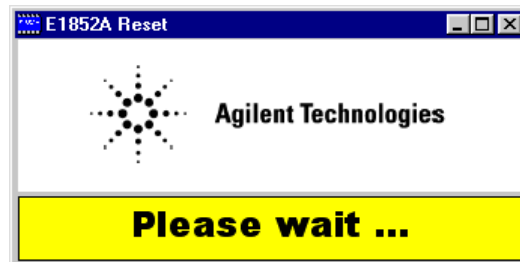

3. If the following message is displayed, the PC has been unable to establish communication with the test set. Confirm all connections and the 'power' indicator on the test set front panel. Click **Retry**.

(If subsequent connection attempts fail, contact the nearest Agilent Technologies office (page 43).



4. Or, if the following message (or similar) is displayed, refer to the Firmware Download procedure in the Maintenance Chapter of the E1852A Bluetooth Test Set *Operating Guide*.

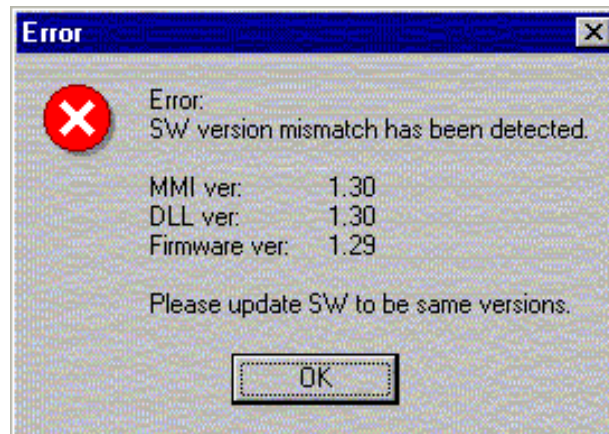

5. When a connection is made, click the **Self-test** tab.

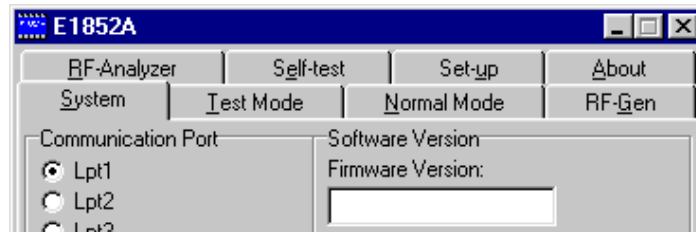

6. Click **Start** to initiate the self test. The **Result** fields are completed during the test.

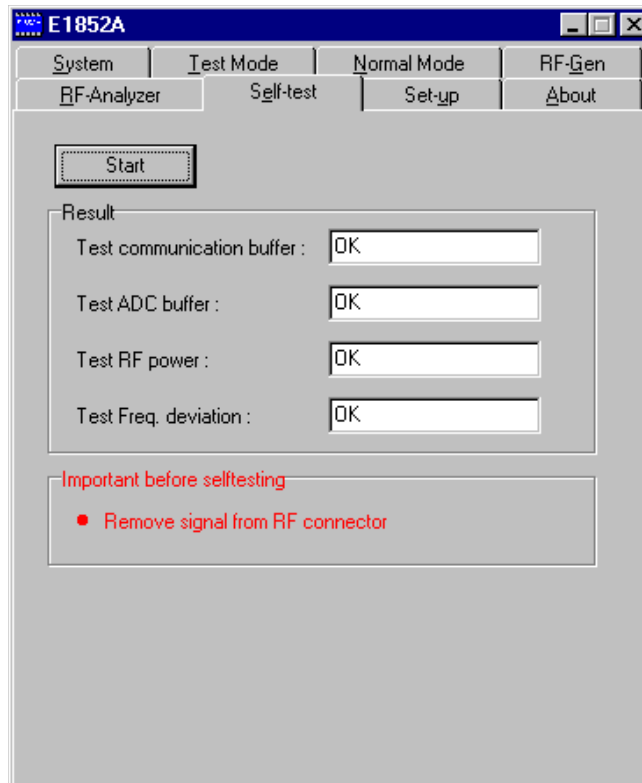

7. Your E1852A Bluetooth Test Set is now ready for use.



Regulatory Information



General Specifications

Environmental	Operating Temperature:	+15 to +45°C	
	Storage Temperature:	-20 to +60°C	
	Humidity:	maximum 80%	
	Altitude:	2000 m	
	EMC:	Conforms to the requirements of the European EMC directive (89/336/EEC)	
	Physical Weight:	3.8 kg Nominal	
Power Requirements	Dimensions: (height x width x depth)	88H x485W x 265D mm nominal	
	Operating Voltage Range:	100 - 120 Vac and 220 - 240 Vac	
	Operating Frequency Range:	50 - 60Hz	
	Power Dissipation:	15 VA (maximum)	
			

Cleaning Use a soft, clean, damp cloth to clean the front-panel and side covers.

Use This instrument is designed for indoor use only.

WARNING Appliance coupler (mains input power cord) is the power disconnect device. Do not position the instrument such that access to the coupler is impaired.

WARNING The E1852A is not fitted with a power switch on the front panel. To allow rapid disconnection from mains power when rack mounted, the E1852A shall only be fitted to a rack cabinet with an easily accessible power isolation switch.

WARNING For continued protection against fire hazard, replace the line fuse only with the same type and line rating (for 100-120V supply use T0.25A 250V, for 220-240V supply use T0.125A 250V). Disconnect the power supply before changing the fuse.

The use of other fuses or materials is prohibited.

WARNING No operator serviceable parts inside. Refer servicing to qualified personnel. To prevent electrical shock do not remove covers.

WARNING If this instrument is not used as specified, the protection provided by the equipment could be impaired. This instrument must be used in a normal condition only (in which all means for protection are intact).

CAUTION This instrument is designed for use in Installation Category II and Pollution Degree 2 per IEC61010 and 60664 respectively.

Compliance and Markings

Electromagnetic Compatibility (EMC)

This product conforms with the protection requirements of European Council Directive 89/336/EEC for Electromagnetic Compatibility (EMC).

The conformity assessment requirements have been met using the technical Construction file route to compliance, using EMC test specifications EN 55011:1991 (Group 1, Class A) and EN 50082-1:1992.

In order to preserve the EMC performance of the product, any cable which becomes worn or damaged must be replaced with the same type and specification.

Refer to the Declaration of Conformity on page 41.

NOTE This product has not been qualified as an intentional radiator. For continued regulatory compliance, this product must not be operated with an antenna attached to its RF Port.

The only exception is where this antenna and the device under test are operated within a shielded enclosure.

This enclosure must ensure the complete isolation of transmitted and/or received signals from the environment outside of the enclosure.

Safety

This instrument has been designed and tested in accordance with publication EN61010-1(1993) / IEC 1010-1(1990) +A1(1992) +A2(1995) / CSA C22.2 No. 1010.1(1993) Safety Requirements for Electrical Equipment for Measurement, Control and Laboratory Use, and has been supplied in a safe condition. The instruction documentation contains information and warnings which must be followed by the user to ensure safe operation and to maintain the instrument in a safe condition.

Markings

The following markings can be found on the rear panel.



The CE mark shows that the product complies with all the relevant European legal Directives.



This is the symbol of an Industrial Scientific and Medical Group 1 Class A product.

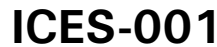

This marking indicates compliance with the Canadian Interference-Causing Equipment Standard which sets out the technical requirements relative to radiated noise emissions from Industrial, Scientific and Medical (ISM) radio frequency generators.



The C-Tick mark is a registered trademark of the Australian Communications Authority. This signifies compliance with the Australian EMC Framework Regulations under the terms of the Radio communications Act of 1992.



The UL mark is a registered trademark of Underwriters Laboratories Inc., and indicates compliance to the United States and Canadian standards laid out by them.

Regulatory Information

Sound Emission

Herstellerbescheinigung

Diese Information steht im Zusammenhang mit den Anforderungen der Maschinenlarminformationsverordnung vom 18 Januar 1991.

- Sound Pressure LpA < 70 dB.
- Am Arbeitsplatz.
- Normaler Betrieb.
- Nach DIN 45635 T. 19 (Typprüfung).

Manufacturers Declaration

This statement is provided to comply with the requirements of the German Sound DIN 45635 T. 19 (Typprüfung).

- Sound Pressure LpA < 70 dB.
- At operator position.
- Normal operation.
- According to ISO 7779 (Type Test).

Declaration of Conformity

according to ISO/IEC Guide 22 and CEN/CENLEC EN45014

Manufacturer's Name: Agilent Technologies UK Limited

Manufacturer's Address: Electronics Products & Solutions Group - Queensferry
South Queensferry
West Lothian, EH30 9TG
Scotland, United Kingdom

Declares that the product

Product Name: Bluetooth Test Set

Model Numbers: E1852A

Product Options: This declaration covers all options of the above product.

Conforms to the following product specifications:

EMC:
IEC 61326-1:1997 + A1:1998 / EN 61326-1:1997 + A1:1998

<u>Standard</u>	<u>Limit</u>
CISPR 11:1990 / EN 55011:1991	Group 1 Class A
IEC 61000-4-2:1995 + A1:1998 / EN 61000-4-2:1995	4kV CD, 8kV AD
IEC 61000-4-3:1995 / EN 61000-4-3:1995	3 V/m, 80-1000 MHz
IEC 61000-4-4:1995 / EN 61000-4-4:1995	0.5kV signal lines, 1kV power lines
IEC 61000-4-5:1995 / EN 61000-4-5:1995	0.5 kV line-line, 1 kV line-ground
IEC 61000-4-6:1996 / EN 61000-4-6:1996	3V, 0.15-80 MHz
IEC 61000-4-11:1994 / EN 61000-4-11:1994	1 cycle, 100%

Safety:

The product conforms to the following safety standards

IEC 61010-1(1990) + A1(1992) + A2(1995) / EN 61010-1:1993 + A2:1995
IEC 60825-1(1993) / EN 60825-1:1994

The product herewith complies with the requirements of the Low Voltage Directive 73/23/EEC, and carries the CE-marking accordingly.

South Queensferry, Scotland

R.M. Evans
**R.M. Evans - Manufacturing
Engineering Manager**

For further information, please contact your local Agilent Technologies sales office, agent, or distributor.

Responsibilities of the Customer

The customer shall provide:

- Access to the products during the specified periods of coverage to perform maintenance
- Adequate working space around the products for servicing by Agilent personnel.
- Access to and use of all information and facilities determined necessary by Agilent to service and/or maintain the products. (Insofar as these items may contain proprietary or classified information, the customer shall assume full responsibility for safeguarding and protection from wrongful use.)
- Routine operator maintenance and cleaning as specified in the Agilent Operating and Service Manuals.
- Consumables such as replacement fuses, etc.

Agilent Sales and Service Offices

In any correspondence or telephone conversations, refer to the power meter by its model number and full serial number. With this information, the Agilent representative can quickly determine whether your unit is still within its warranty period.

UNITED STATES	Agilent Technologies (tel) 1 800 452 4844
CANADA	Agilent Technologies Canada Inc. Test & Measurement (tel) 1 877 894 4414
EUROPE	Agilent Technologies Test & Measurement European Marketing Organization (tel) (31 20) 547 2000
JAPAN	Agilent Technologies Japan Ltd. (tel) (81) 426 56 7832 (fax) (81) 426 56 7840
LATIN AMERICA	Agilent Technologies Latin America Region Headquarters, USA (tel) (305) 267 4245 (fax) (305) 267 4286
AUSTRALIA and NEW ZEALAND	Agilent Technologies Australia Pty Ltd. (tel) 1-800 629 4852 (Australia) (fax) (61 3) 9272 0749 (Australia) (tel) 0-800 738 378 (New Zealand) (fax) (64 4) 802 6881 (New Zealand)
ASIA PACIFIC	Agilent Technologies, Hong Kong (tel) (852) 3197 7777 (fax) (852) 2506 9284
